

OWNERS MANUAL

#6

MIKRO-ATOMIZER

- INSTALLATION
- MAINTENANCE
- OPERATION
- LUBRICATION
- PARTS LISTS



MikroPul

HOSOKAWA MICRON INTERNATIONAL INC.

10 Chatham Road, Summit, NJ 07901 — (201) 273-6360/Fax (201) 273-9091

CONTENTS

	<u>PAGE NO.</u>
Foreward	2
Design Data	2
Installation	3
Safety Recommendations	3-4
Initial Start-Up Procedure	4
Shut Down Sequence	4
Principal of Operation	4-5
Regulation of the Particle Size	5
Relative Sizes of Grinds Comparative to Set-Up	5-6
Disassembly	6-7
Hammer Replacement	7
Separator Blade Replacement	7-8
Lubrication	8
Options	8
Parts List	10-14

ILLUSTRATIONS

	<u>PAGE NO.</u>
General Assembly of #6 Mikro-Atomizer Rotor	6
Cross Section of #6 Mikro-Atomizer	9
Pillow Block Assembly	11-12
Feed Screw Mechanism Assembly	15
Arrangement of #6 Mikro-Atomizer	16

FOREWORD

The No. 6 Mikro Atomizer has successfully proven itself to be the finest unit of precision grinding equipment in the field of particle reduction. The ease of operation, technological advancements in the classification technique and robust design has made it the standard of the industry. Besides a performance guaranty, we offer service and consultation by our factory trained engineers relating to maintenance and application to insure maximum operating efficiency. We suggest you become familiar with the contents of this pamphlet prior to installation and operation.

WHEN ORDERING REPLACEMENT PARTS
PLEASE SUPPLY THE FOLLOWING INFORMATION:

Model No. 6 Mikro Atomizer

Serial No. _____

DESIGN DATA

Main Drive	20 to 25 HP
Rotor Speed	7000 RPM Max.
Maximum Clearance Between Separator Blades and Dispersion Ring018 or .030
Approximate Airflow Required	1000 to 1200 CFM
Approximate Static Pressure	1.0" w.c. Neg.
Power Requirements	230/460 volts AC 3PH, 60HZ
Weight (Approximately)	2,500 lbs.

INSTALLATION

1. Concrete floor should be level, or the steel pier supports should be level and square.
2. The concrete floor should be reinforced and not less than 6" thick.
3. See arrangement drawing for lay out and bolt pattern.
4. Provision for make up air must be considered.
5. Grout in place without stressing the structural frame.
6. Ground the frame.
7. Sufficient space for upper grinding chamber swing should be allowed for.
8. Provision should be made for overhead rail with one (1) ton hoist capability.
9. Inspect mill interior prior to start up.
10. Install an ammeter to monitor drive motor current consumption.
11. Install a manometer to monitor static pressure at discharge of mill.
12. Lubricate the pillow blocks and feed screw assembly prior to start up.
(see "Lubrication" section of this manual).

SAFETY RECOMMENDATIONS FOR #6 MIKRO ATOMIZER

IMPORTANT: Prior to operating this equipment, read this list of safety recommendations through in its entirety, along with the Operating Instructions.

1. Be sure mill is properly grounded electrically; i.e., the ground wire from motor(s) to receptacles with proper grounds, along with static grounding (when a potential problem).
2. Avoid the use of extension cords. If necessary, use an extension cord of sufficient ampere and not of excessive length (applicable only for portable mills).
3. When opening the mill grinding chamber or when working on the mill drive, be certain the power supply to the mill is off and locked out.
4. Replace belts or flexible couplings at first sign of wear, slippage or fraying.
5. When operating the mill, all guards should be in place for protection against injury from moving parts.
6. If a motor is overloaded and the starter heaters and/or circuit breaker(s) are tripped, never install higher rated heaters or circuit breakers as a correction. The cause of overload must be investigated and corrected before attempting to restart the motor.
7. If the material being pulverized is toxic, proper inhalation masks should be worn and no smoking rules should be observed.
8. If an explosive environment exists around the mill, all electrical motors and controls must be explosion-proof and maintenance to the equipment should be performed with non-sparking tools.
9. To eliminate the chance of sparking occurring within the mill, all metallic scrap (tramp) must be positively separated from the feed material before it enters the grinding chamber of the mill. This can be accomplished by the use of scalping screens, magnetic separators, etc.
10. While working around the mill, safety glasses should be worn as eye protection.
11. Due to the extreme levels of noise that exist around the grinding equipment while in operation, proper ear protection should be worn by equipment operators, maintenance personnel, and anyone within the vicinity of the equipment. OSHA makes some specific guidelines to follow in this respect.
12. Should abnormal levels of vibration or noise develop, immediately shut off the equipment, investigate, and correct.
13. A preventative maintenance program should be developed so that the equipment is regularly lubricated and to aid in early discovery of equipment malfunctions.

Safety Recommendations (Cont.)

14. Keep hands and clothing clear of feed hopper opening, air inlets and all moving parts.
15. After working on internal components of a mill (i.e., parts replacement, adjustment, or

maintenance) the rotor shaft assembly should be rotated by hand to assure freedom of rotation. The motor should then be "bumped" on and off once as a further check to verify that clearances are proper. If a mechanical contacting sound is detected, the mill will have to be readjusted to proper clearances (contact MikroPul for this information).

INITIAL START-UP PROCEDURE

Preliminary Checks

1. Verify proper clearance between separator blades and dispersion rings. (.018" or .030")
2. Verify clearance between both exhaust fans and housing, .020" minimum.
3. Close mill.
4. Manually rotate rotor shaft for 360° to verify that clearance is maintained in upper grinding chamber. Any drag noted will require re-adjustment. (see maintenance section for detailed procedure).
5. Start rotor. Note idle load.
6. Start exhaust fan.
7. Start feed at lowest RPM.
8. Increase feed screw RPM to a point of non-surfing load indicated by the ammeter on the main drive motor, without exceeding maximum load rating of the motor.

NOTE: Once feed screw rate has been established, unit may be fed from day to day at same rate.

SHUT DOWN SEQUENCE

1. Stop feed motor.
2. Permit the mill to operate without feed for a period of three (3) to six (6) minutes so that the grinding chamber may clear itself.
3. Shut down the fan.
4. Shut down the rotor.

MIKRO ATOMIZER

PRINCIPLE OF OPERATION

The exhaust fans mounted on both ends of the rotor shaft, depending upon their diameters and rotational speed, produce a movement of air between 800 CFM to 1000 CFM. The air enters the mill primarily through annular inlets which surround the grinding chamber for 360° on both sides and secondarily through the feed inlet. Internal design of the grinding chamber and equal adjustment of components within the mill will promote a separation of the airflows and provide an equal and balanced dual passage of air through the left and right separator blade assemblies. Airflow con-

tinues through the central port in the dispersion rings and flows into the exhaust fan housing where it is discharged through the duct by the positive displacement of air induced by the exhaust fan rotation. Once these circulatory paths are stabilized the dual passage of air through the left and right sides of the mill will maintain an equilibrium providing two separate areas for classification to take place.

When material is introduced into the feed inlet, it

PRINCIPLE OF OPERATION (cont)

is partially dispersed by the incoming air and drawn into the grinding chamber. Here the material is fragmented and reduced in size by repeated impact imparted to the particle by the hammers, forcing the particle to take on a tangential direction into the multiple deflector liner. The multiple deflector liner is designed to reverse the direction of the particle almost 180°, creating

a head-on condition for additional impact with the face of the hammers. When the particle is reduced in size sufficiently to allow the normal circulatory airflows within the mill to act upon it, the particle is directed in front of the separator blades. Here it is either accepted and passed out of the mill or rejected and returned to the grinding chamber for further reduction.

REGULATION OF THE PARTICLE SIZE

The Mikor Atomizer has four (4) standard internal setups which provide the range and latitude for the grinding specification. These normal setups are identified as:

1. The course grinding set up
2. The medium grinding set up
3. The fine grinding set up
4. The pigment grinding set up

Prior to purchase, the Pulverizing Machinery Laboratory will test the material and determine which of the above set-ups will be most suitable for the material and the grinding specification.

This selection determines the horsepower necessary to meet the requirement for output capacity, the particle size range the Mikro Atomizer will produce, the exhaust fan design and diameter to control the airflow, the clearance between the dispersion rings and the separator blades to limit oversized particles, the number and axial length of the separator blades to control the particle size distribution and air velocity, and

the rotor shaft RPM which will also control the particle size distribution and CFM.

In each of the setups, the coarseness of the grinding specification can be increased by one or more of the following means:

- a) using larger diameter fans on the rotor shaft
- b) using separator blades of shorter axial length
- c) increasing separator blade clearance equally on both the left and right sides.
- d) reducing the thickness of the annular inlets to allow more airflow into the mill by reduced obstructions
- e) reducing the rotor shaft speed
- f) reducing the width of the blades
- g) reducing the number of blades
- h) reducing the number of hammers
- i) using smooth liners

Conversely, to increase the fineness of the grind, the opposite of any of the preceding approaches can be taken.

RELATIVE SIZES OF GRINDS COMPARATIVE TO SETUP — #6 M-A

ROTOR RPM	FAN DIAMETER	SEP. HUB	24-BLADE SETUP	SEPARATOR BLADES SIZE	DISP. RING	RELATIVE PART. SIZE
7,000	11¼" L 146	37273	5581	1-1/8" x ¾" LH	37453	1.00
	11¼" R 147		5579	1-1/8" x ¾" RH	37452	
7,000	12½" L 144	37273	5581	1-1/8" x ¾" LH	37453	1.06
	12½" R 145		5579	1-1/8" x ¾" RH	37452	
7,000	11¼" L 146	37273	5543	13/16" x ¾" LH	37455	1.17
	11¼" R 147		5541	13/16" x ¾" RH	3754	
7,000	12½" L 144	37273	5543	13/16" x ¾" LH	37455	1.24
	12½" R 145		5541	13/16" x ¾" RH	37454	
6,000	12½" L 144	37273	5581	1-1/8" x ¾" LH	37453	1.24
	12½" R 145		5579	1-1/8" x ¾" RH	37452	
6,000	14" L 142	37273	5581	1-1/8" x ¾" LH	37453	1.35
	14" R 143		5579	1-1/8" x ¾" RH	37452	
6,000	12½" L 144	37273	5543	13/16" x ¾" LH	37455	1.46
	12½" R 145		5541	13/16" x ¾" RH	37454	

RELATIVE SIZES OF GRINDS COMPARATIVE TO SETUP — #6 M-A (Cont.)

ROTOR RPM	FAN DIA.	SEP. HUB	24-BLADE SETUP	SEPARATOR BLADES SIZE	DISP. RING	RELATIVE PART. SIZE	
5,000	14" L	142	37273	5581	1-1/8" x 3/4" LH	37453	1.58
	14" R	143		5579	1-1/8" x 3/4" RH	37452	
6,000	14" L	142	37273	5543	13/16" x 3/4" LH	37455	1.59
	14" R	143		5541	13/16" x 3/4" RH	37454	
7,000	11 1/4" L	146	37271	5549	7/16" x 3/4" LH	37455	1.66
	11 1/4" R	147		5546	7/16" x 3/4" RH	37454	
7,000	12 1/2" L	144	37271	5549	7/16" x 3/4" LH	37455	1.74
	12 1/2" R	145		5546	7/16" x 3/4" RH	37454	
5,000	14" L	142	37273	5543	13/16" x 3/4" LH	37455	1.86
	14" R	143		5541	13/16" x 3/4" RH	37454	
6,000	12 1/2" L	144	37271	5549	7/16" x 3/4" LH	37455	2.10
	12 1/2" R	145		5546	7/16" x 3/4" RH	37454	
6,000	14" L	142	37271	5549	7/16" x 3/4" LH	37455	2.26
	14" R	143		5546	7/16" x 3/4" RH	37454	
5,000	14" L	142	37271	5549	7/16" x 3/4" LH	37455	2.61
	14" R	145		5546	7/16" x 3/4" RH	37454	

INDIVIDUAL BLADE NO.

7/16" x 3/4" LH 5548

7/16" x 3/4" RH 5545

13/16" x 3/4" LH 5542

13/16" x 3/4" RH 5549

1-1/8" x 3/4" LH 5580

1-1/8" x 3/4" RH 5578

36-BLADE SETUP

5522

5521

DISASSEMBLY

1. Remove the duct work.
2. Insure the keyway on the rotor shaft is at top dead center position.
3. Remove the bolts on the grinding chamber and swing bolts on both sides of the exhaust fan housing.
4. Raise the cover to the fully open position.
5. Loosen drive belts or disconnect the coupling.
6. Remove the two (2) bolts on each pillow block.
7. Install sling with two (2) point suspension between the pillow blocks and the exhaust fan housing.
8. Carefully lift the rotor assembly clear of the housing.

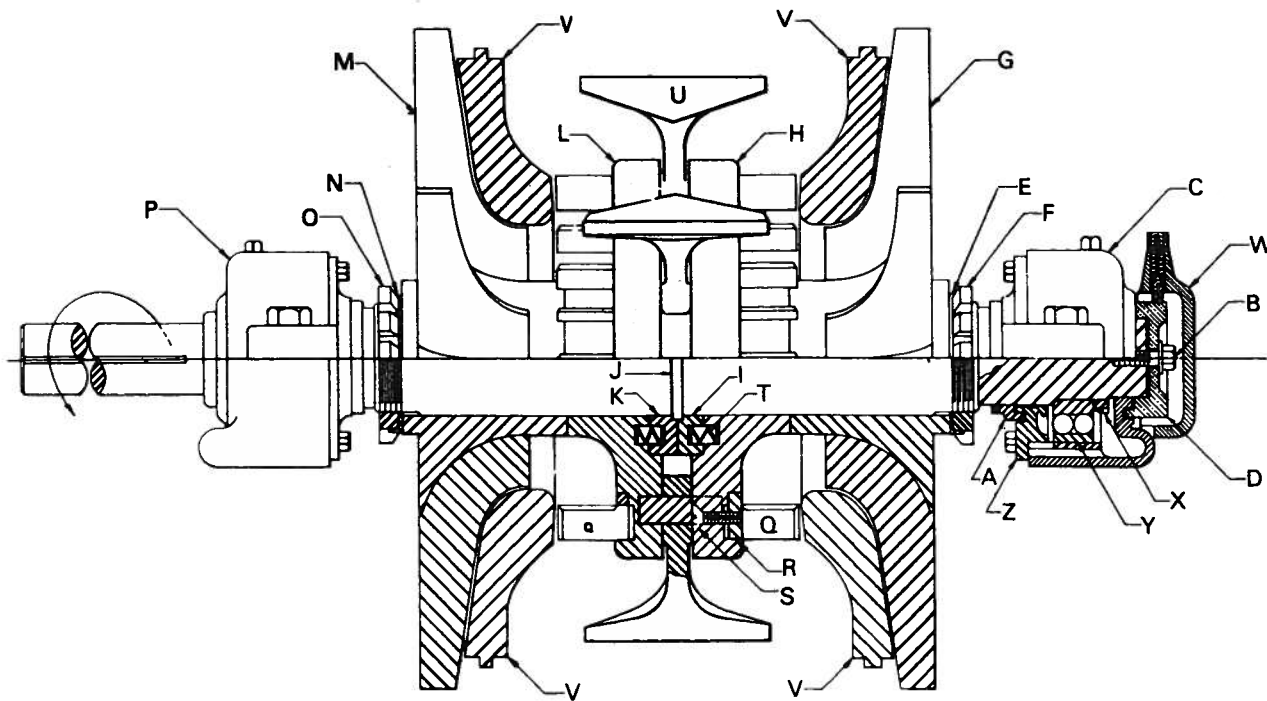

GENERAL ASSEMBLY OF #6 MIKRO ATOMIZER ROTOR

DISASSEMBLY (cont.)

9. Remove the static collector housing "W" containing the brush from opposite drive side.
10. Remove the bolt "B" from the end of the shaft, along with the flinger.
11. Remove the four (4) bolts from the pillow block end cover "Z" and slip the pillow block "C" off the shaft by pulling on the pillow block ears.
12. The exposed bearing "Y" can now be removed by disengaging the tab lock-washer and locknut "X", and then use a puller to remove the bearing.
13. Remove the loose end cover "Z" and inner flinger "A" by loosening the set screw(s).
14. Disengage the tab lockwasher "E" and remove the adjusting locknut "F".
15. In turn, pull off the fan "G", rotor/separator hub. "H", the six springs "T", the spring retaining collar "I" and remove the hammers "U".
16. If it is desired to remove the drive side pillow block, the same procedure should be followed after removal of the sheave or coupling.
17. Disengage the tab lockwasher "N" and back off the adjusting locknut "O" about $\frac{1}{4}$ ".
18. Push the fan "M", rotor/separator hub "L" and spring retaining collar "K" to the left a sufficient distance to permit the removal of the split thrust ring "J".
19. In turn, pull off the spring retaining collar "K", the remaining six springs "T", the rotor/separator hub "L", and the fan "M".

HAMMER REPLACEMENT

When replacing hammers it is only necessary to remove the opposite drive side pillow block and bearing assembly and to shift the fan "G" and hub "H" to the right about 2". The remainder of the rotor assembly need not be disturbed. New hammers should be installed so that the flat faces of the hammers lead in a clockwise direction when viewed from the pulley (drive) end of the shaft.

It should be noted that new sets of hammers are furnished as six (6) pairs with each pair stamped on the back of the cross bar with an identical number. These pairs of hammers are identical in

weight and must be installed diametrically opposite one another. This is most important to insure proper balance.

When the rotor is reassembled and bolted in place in the main housing, the specified clearance (.018" or .030") between the separator blades "Q" and the dispersion rings "V" must be readjusted using the feeler gauge supplied with the machine. Adjustment is accomplished by turning the Locknuts "F" and "O" with a suitable spanner wrench and then resecuring the locknuts with the proper tabs on the lockwasher "E" and "N".

SEPARATOR BLADE REPLACEMENT

To replace separator blades, remove the counter-sunk screws "S" that hold the separator blade retaining disc "R" to the rotor/separator hub "H" or "L". The retaining disc can then be removed and the separator blades can be slid out of their slots. When replacing the blades, those stamped "R" are for the right-hand separator assembly (referenced by standing facing the mill from the feed screw side) and those stamped "L" are for the left-hand separator assembly.

When the rotor is reassembled and bolted in place in the main housing, the specified clearance (.018 or .030") between the separator blades "Q" and the dispersion rings "V" must be readjusted using the feeler gauge supplied with the machine. Adjustment is accomplished by turning the locknuts "F" and "O" with a suitable spanner wrench and then resecuring the locknuts with the proper tabs on the lockwashers "E" and "N". The dispersion rings "V" are bolted in the grinding chamber and

are not an integral part of the rotor assembly.

CAUTION: When reassembling the rotor, be positive that the compression springs "T" and "K" are properly in place. Also, when adjusting for the separator blade clearance, it is wise to

start with the rotor/separator hubs "H" and "L" spread further apart than necessary and then increase the clearances by tightening of the locknuts. This will assure proper contact between the locknuts and the fan hubs, as well as between the fan hubs and the rotor/separator hubs.

LUBRICATION

The pillow block (rotor) bearings are provided with spring-cover oil cups attached to the bottom of each pillow block housing (standard equipment). The oil level should be 1/8" from the top of the oil cup when the machine is not running. When the mill is running, the level in the cup will be lowered as part of the oil is carried into the bearing housing. Oil should not be added while the mill is running to raise the oil back to its original level. This results in an excessive amount of oil in the bearing with consequent overheating and leakage around the shaft. We recommend using SAE #30 wt. cylinder oil for these bearings. At reduced speeds and cooler grinding temperatures, SAE #20 wt. cylinder oil is recommended. The levels of oil in the cups should be checked on a daily basis to be sure the oil is at proper level. It is also best to

flush the pillow blocks out once a month by draining the used oil and pouring clean oil in thru the top plug hole and letting it run out thru the bottom plug hole.

The No. 6 MA feed screw is carried on bronze bushings which are equipped with Zerk fittings for No. 2 cup grease. The gear box feed drive shaft is supported by two (2) ball bearings. These bearings are lubricated by cup grease directly thru Zerk fittings. Lubrication frequency for the Zerk fittings should be approximately once a week. The grease that is packed in the gear box of the feed screw assembly should be changed every three months.

OPTIONS

1. Water-cooled shaft and pillow blocks.
2. Bijur lubrication system.
3. Mikro Monitor load controller (automatic feed switch).
4. Seco speed controller for feed.

For information and/or pricing on these and any other parts, contact your local MikroPul sales representative or our main office in Summit, New Jersey.

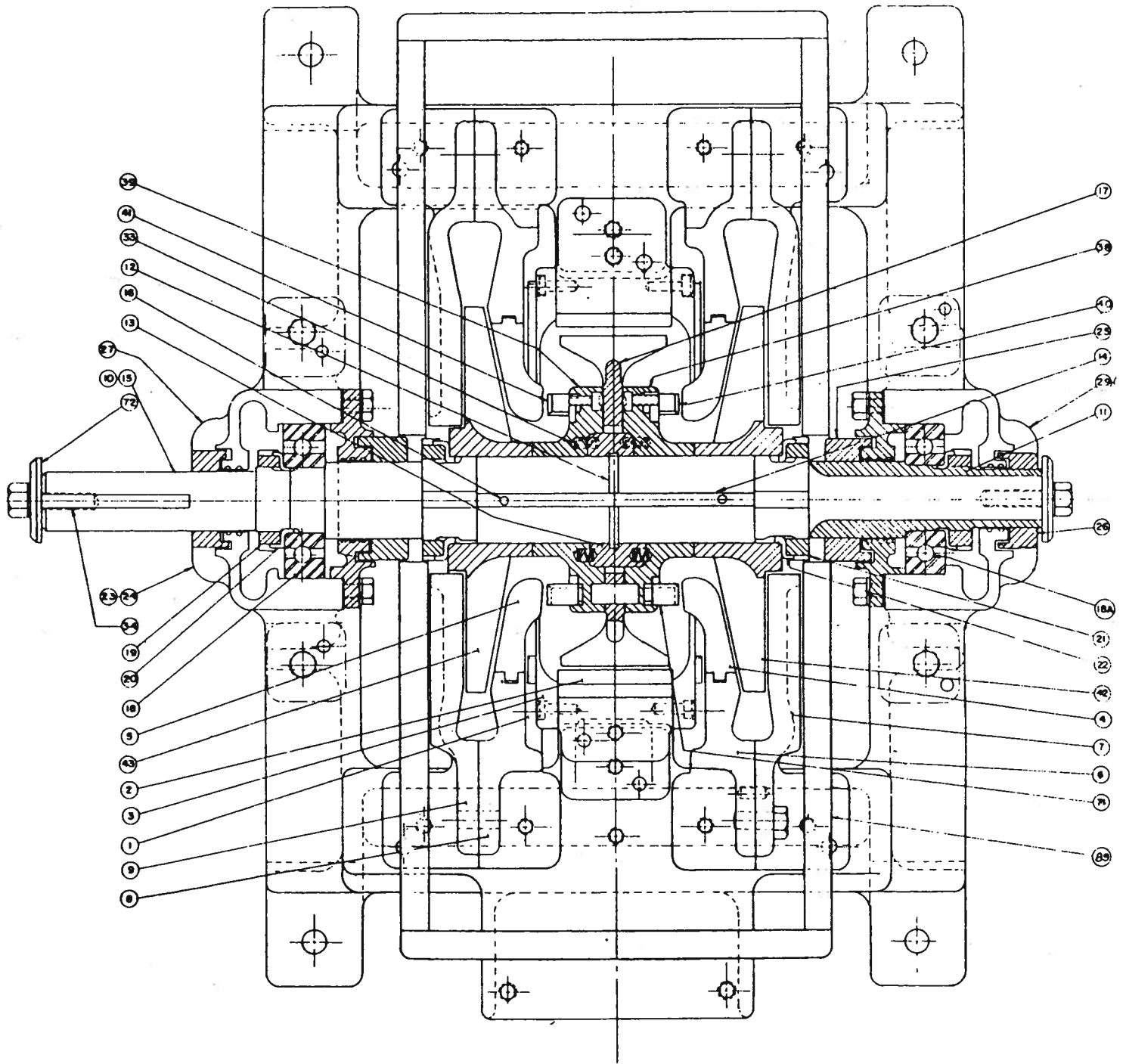

CROSS SECTION OF MIKRO ATOMIZER

63262

Ref. No.	Cat. No.	Name of Part
.	59237	Upper Grinding Chamber — NI Resist
.	29170	Multiple Deflector Liner, Upper Half With (10) Flat Head Machine Screws — S.S. Type
.	2957	Recess Liner With (2) Tire Bolts & Nuts
.	59146	Feed Inlet Cover — NI Resist
.	34924	Feed Inlet Cover — Aluminum
1	5789	Lower Grinding Chamber — NI Resist
2	29179	Multiple Deflector Liner, Lower Half With (10) Flat Head Machine Screws
3	29168	Annular Deflector Sets — NI-Resist, Standard Radius 1/4 x 1" S.S. Allen Head Cap Screws
3	29166	L.H. Annular Deflector Set — Wide Fins — NI Resist
3	29167	R.H. Annular Deflector Set — Wide Fins — NI Resist
4	37264	R.H. Dispersion Ring — NI Resist For 7-3/4" Dia. Sep. Wheel, 13/16 or 7/16" Deep, Straight Blade Type
4	37274	R.H. Dispersion Ring — NI Resist 1-1/8" Deep Straight Sep. Blades
5	37267	L.H. Dispersion Ring — NI Resist For 7-3/4" Dia. Sep. Wheel 13/16 or 7/16" Straight Blade Type
5	37275	L.H. Dispersion Ring — NI Resist For 1-1/8" Deep Straight Sep. Blades
.	28255	Right Hand Inside Upper Fan Casing — NI Resist
6	28263	Right Hand Inside Lower Fan Casing — NI Resist
.	28271	Right Hand Outside Upper Fan Casing — NI Resist
7	28279	Right Hand Outside Lower Fan Casing — NI Resist
.	28251	Left Hand Inside Upper Fan Casing — NI Resist
8	28259	Left Hand Inside Lower Fan Casing — NI Resist
.	28267	Left Hand Outside Upper Fan Casing — NI Resist
9	28275	Left Hand Outside Lower Fan Casing — NI Resist
.	25136	Threaded Rod Ends — Steel
.	31139	Groove Pins — C.R.S.
.	31179	Groove Pins — C.R.S.
.	2542	Swing Eye Bolts — Steel
.	2561	Eye Nuts — Steel
.		5/8" Flat Washers
10	36127	Rotor Shaft Assembly — 416 S.S.
11	37262	Rotor Sleeve For Opp. Drive — C.R.S.
12	37146	Split Thrust Rings — C.R.S.
13	37261	Hubs — 304 S.S.
14	31134	Keys — 304 S.S.
15	36126	Rotor Shaft — 416 S.S.
16	3131	Dowel Pins — 304
17	24160	Set of (12) Stellite Tipped Hammers, 4" Face 304 Stainless Steel
17	24163	Set of (12) Stellite Tipped Hammers, 304 S.S.

*Not Indicated on Illustration

Ref. No.

Cat. No.

Name of Part

UNITS PRIOR TO JUNE 1954

18	5337	#2309 SKF Bearings (Same Bearing In Each Pillow Block)
19	2595	#N09 SKF Lock Nuts On Bearing
20	25111	#W09 SKF Lock Washers On Bearing
21	2597	#N12 SKF Lock Nuts
22	25113	#W12 SKF Lock Washers
23	631	Pillow Block Assembly (Held) For Drive Side
24	2865	Housing
25	3548	Flinger 2-1/4" Bore
26	3550	Flinger 1-11/16" Bore
27	35125	Gasket
28	5995	End Cover
29	6225	Pillow Block Assembly (Free) Opp. Drive Side
30	2859	Housing
32	59269	End Cover

UNITS AFTER JUNE 1954

18A	5344	#6309-C3 SKF Ball Bearing (Deep. Groove) Held
18B	5351	N-309-M-C3 SKF Roller Bearing (Cylindrical) Drive Side
19	25111	#W-09 SKF Washer (Lock)
20	2595	#N-09 SKF Lock Nuts
23	6322	Pillow Block Assembly For Drive Side
24	2865	Housing
25	3548	Rear Flinger 2-1/4" Bore
26	3550	Front Flinger 1-11/16" Bore
27	35125	End Cover Gasket
28	5915	End Cover
29	6321	Pillow Block Assembly Opp. Drive
32	5914	End Cover
.	37112	Spacer Sleeve
.	37113	Spacer Sleeve

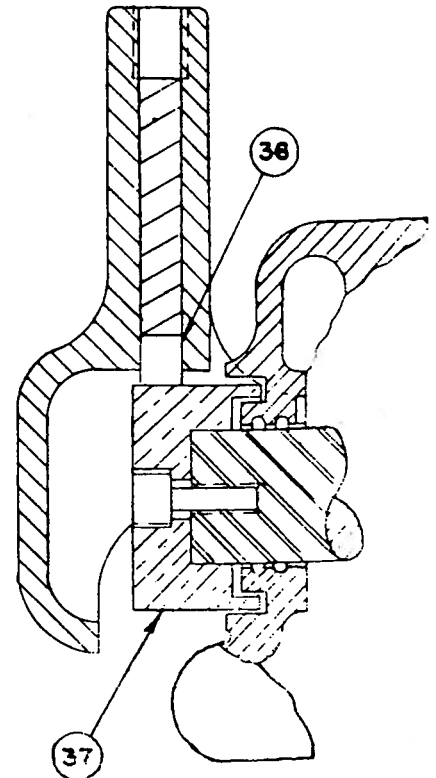
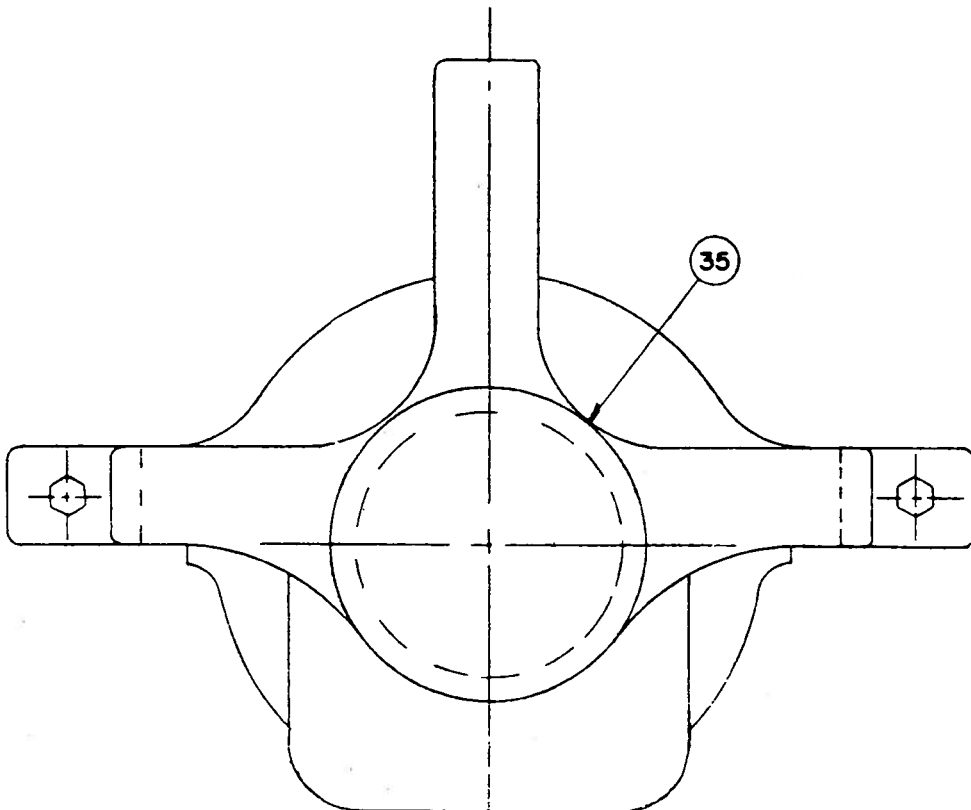

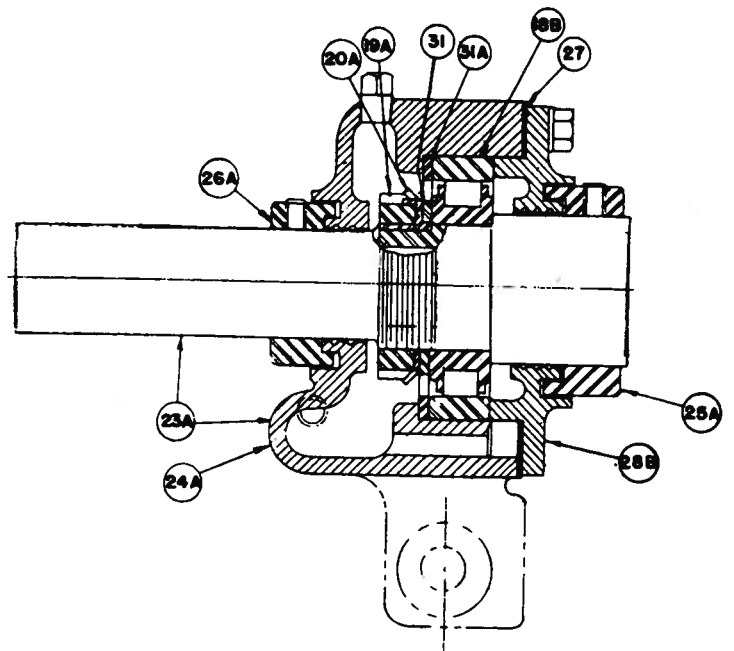
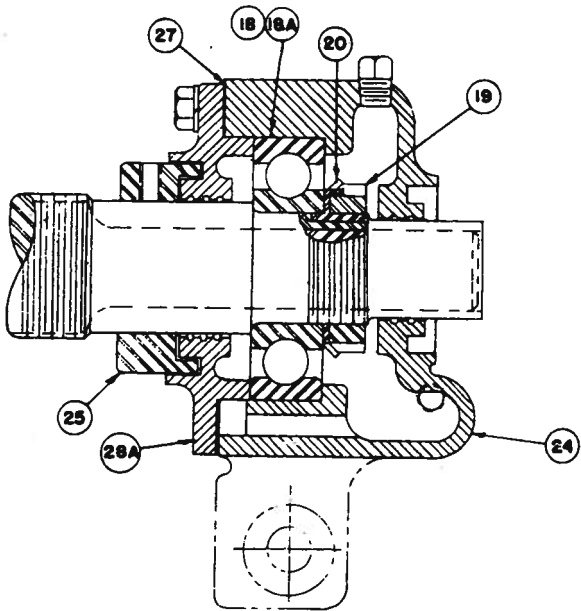
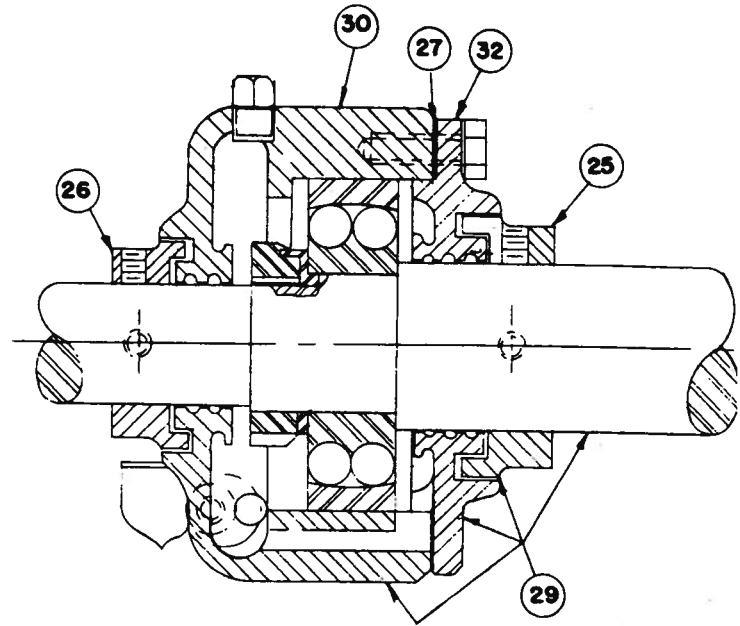
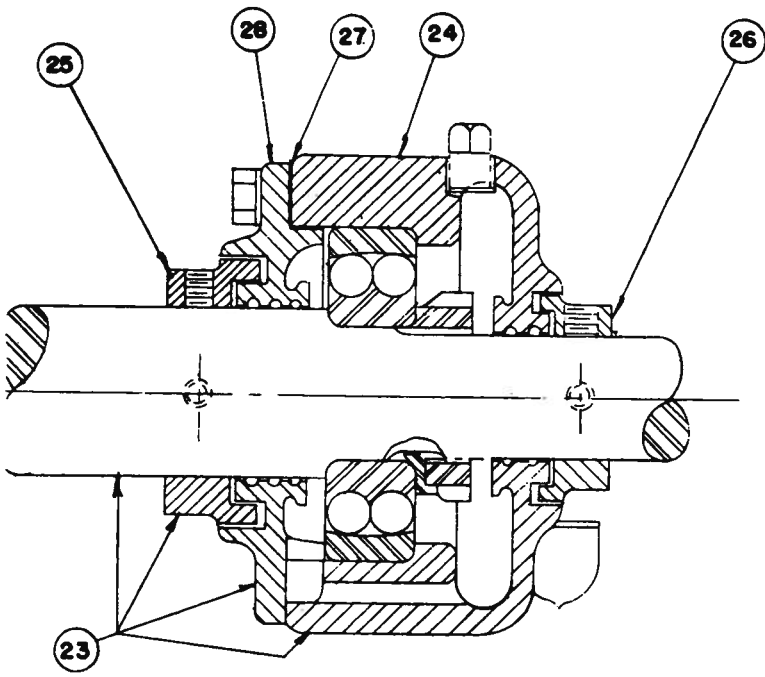

Ref. No.	Cat. No.	Name of Part
.	2579	Washers
33	2638	V-91 Die Springs
34	3197	Key — C.R.S.
35	13239	Static Collector Assembly — Bronze
.	2366	Guard — C.I.
36		Graphite Brush
37	37147	Collector Ring — Bronze
38	635	Separating Wheel Assembly R.H. With 7/16 x 3/4" Removable Blade, Flat Ret. Disc
38	6329	Separating Wheel Assembly R.H. With 13/16 x 3/4" Removable Blades, Flat Ret. Disc.
38	637	Separating Wheel Assembly R.H. With 1-1/8 x 3/4" Removable Blade, Flat Ret. Disc 2-1/4" Hub
39	634	Separating Wheel Assembly L.H. With 7/16 x 3/4" Removable Blade, Flat Ret. Disc.
39	6328	Separating Wheel Assembly L.H. With 13/16 x 3/4" Removable Blades, Flat Ret. Disc.
39	636	Separating Wheel Assembly L.H. With 1-1/8 x 3/4" Removable Blade, Flat Ret. Disc. 2 1/4 Hub
40	5541	R.H. Separator Wheel Blades — Stellite (P.C.) 13/16" Lg. Use With 6329
40	5579	R.H. Separator Wheel Blades — Stellite 1-1/8" Extended End (P.C.) Use With 637
40	5546	R.H. Separator Wheel Blades — Stellite (P.C.) 7/16" Lg. Use With 635
41	5543	L.H. Separator Wheel Blades — Stellite (P.C.) 13/16" Lg. Use With 6328
41	5581	L.H. Separator Wheel Blades — Stellite 1-1/8" Extended End (P.C.) Use With 636
41	5549	L.H. Separator Wheel Blades (P.C.) 7/16" Lg. Use With 634 Stellite
42	142	14" Dia. Exhaust Fan (6) Straight Blades, L.H.
43	143	14" Dia. Exhaust Fan (6) Straight Blades, R.H.
42	144	12-1/2" Dia. Exhaust Fan (6) Straight Blades, L.H.
43	145	12-1/2" Dia. Exhaust Fan (6) Straight Blades, R.H.
42	146	11-1/4" Dia. Exhaust Fan (6) Straight Blades, L.H.
43	147	11-1/4" Dia. Exhaust Fan (6) Straight Blades, R.H.
42	1410	14" Dia. Exhaust Fan (12) Straight Blades, L.H.
43	1411	14" Dia. Exhaust Fan (12) Straight Blades, R.H.
42	1412	14" Dia. Exhaust Fan (6) Blade — Forward Curved Tips L.H.
43	1413	14" Dia. Exhaust Fan (6) Blade — Forward Curved Tips R.H.
44	6330	Feed Screw Mechanism Assembly 5:1 Gears, 1-3/4 Dia. Feed Screws
44A	6331	Feed Screw Mechanism Assembly 10:1 Gears, 1-3/4 Dia. Feed Screws
44B	6332	Feed Screw Mechanism Assembly 20:1 Gears, 1-3/4" Dia. Feed Screws
44C	6333	6M-A Feed Screw Mechanism Assembly 5:1 Gears With 2-15/16 Dia. Feed Screw
44D	6334	6M-A Feed Screw Mechanism Assembly 10:1 Gears With 2-15/16 Dia. Feed Screw

* Not Indicated On Illustration

Ref. No.	Cat. No.	Name of Part
44E	6335	6M-A Feed Screw Mechanism Assembly 20 1 Gears With 2-15/16 Dia. Feed Screw
45	5329	BS 30 Schatz Bearing
46	16117	1-3/4" Dia. Helicoid Flight Feed Screw, 1-3/8" Pitch R.H.
46	16122	2-15/16" Dia. Feed Screw, 2" Pitch R.H.
47	3256	Garlock Mounting Plates
48	35136	#213 Garlock Kloxure
49	225	R.H. 8P Single Steel Worm and Taper Pin, For 20:1 Ratio
49A	227	R.H. 8P Double Steel Worm and Taper Pin, For 10:1 Ratio
49B	229	R.H. 8P Quad. Steel Worm and Taper Pin, For 5:1 Ratio
50	2224	R.H. 8P 20T Single Bronze Worm Gear For 20:1 Ratio
50A	2228	R.H. 8P 20T Double Bronze Worm Gear For 10:1 Ratio
50B	2231	R.H. 8P 20T Quad Bronze Worm Gear For 5:1 Ratio
51		3/4 x 2-1/4" Lg. Hardened Set Screw
52		3/4" Locknut
53	2536	Keywasher
54	5959	Gear Box Cover
55	5922	Bearing Retaining Cover
56	35126	Gasket
57	37202	Bronze Adapter
58	37197	Bronze Adapter
59		#2 Taper Pin, 1-1/4" Long
60	3544	Set Screw Retainer
61	5330	1250 Schatz Bearing
62	3620	Feed Drive Shaft
63	62187	Gear Box Casting With Bushings And S.S. Face Plate
.	28249	Feed Through For 2-15/16" Feed Screws — NI Resist
.		Feed Through For 1-3/4" Feed Screws — NI Resist
.	5292	Feed Through Pedestal — C.I.
64		1/2" x 1" Lg. R.H. Hex Head Cap Screw, Hardened
65		#3 Taper Pin
.	2754	Hopper Assembly For PS-214 Feed Through — 304SS
.	2753	Hopper Assembly For PS-194 Feed Through — 304SS
.	5247	Slide Base Assembly — C.I.
.	37148	Sleeve For 2-3/8" Bore In Feed Through — 304SS

EXHAUST SYSTEM

.	1282	Exhaust Manifold "Y" Connection
.	31181	3/8 x 1-1/2" Knurled Pin — C.R.S.
.	25136	Threaded Rod Ends — Steel
.	12106	5-1/2" Sq. Vertical Duct — S.S. Type
.	12112	Long Sweep Venturi Ell — S.S. Type
.	1269	5-1/2" Sq. Duct 48" Lg. — S.S. Type
.	12142	5-1/2" Sq. 45° Ell — S.S. Type
.	3516	5-1/2 x 5-1/2" Sq. Gasket
.	35193	Exhaust Manifold Lower Flange Gaskets
.	35194	Exhaust Manifold Upper Flange Gaskets

* Not Indicated On Illustration

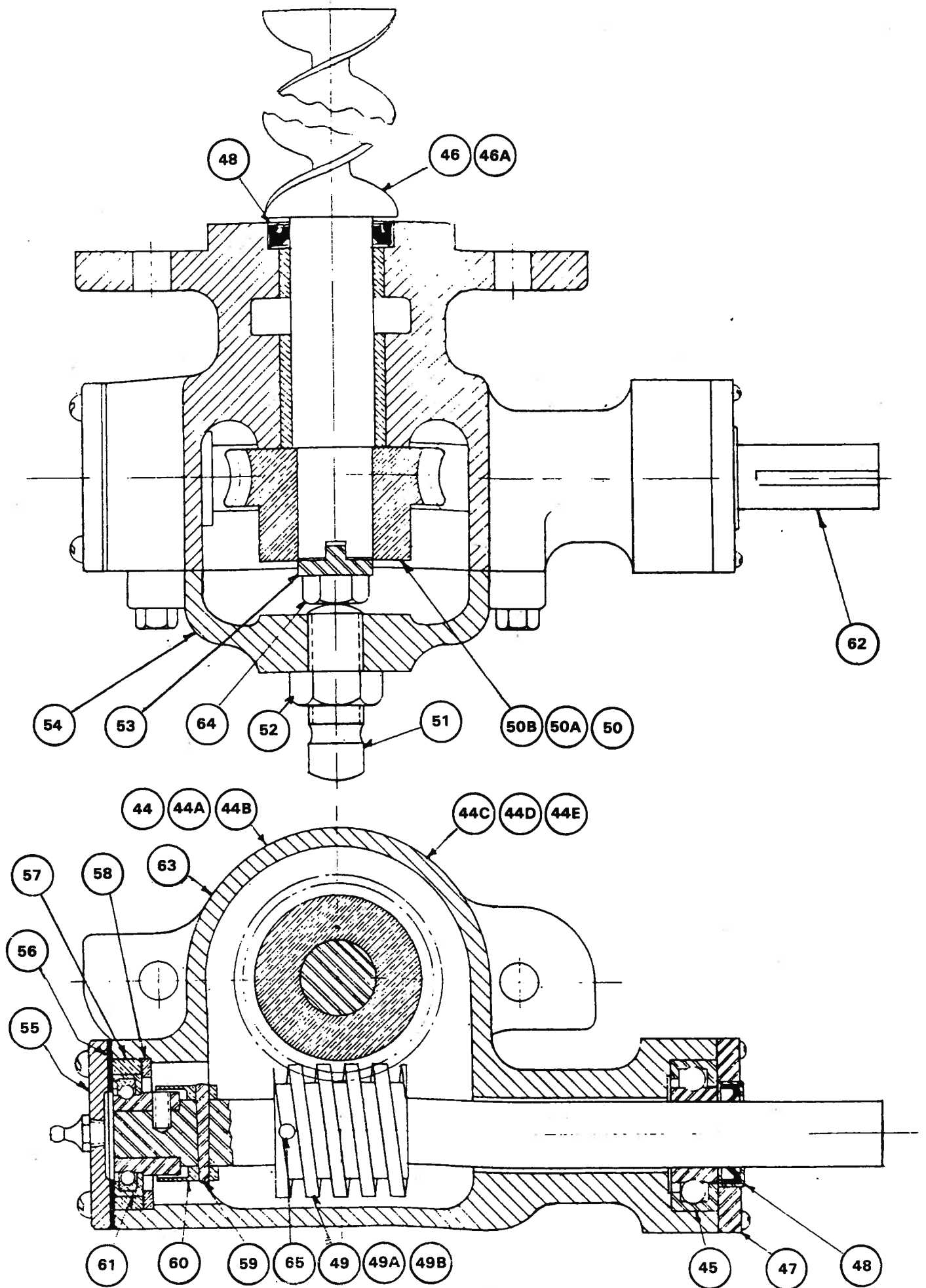

FEED SCREW MECHANISM ASSEMBLY

